



When Time **Matters!**

VariVent (Energy Control System)



A Smart Solution to an Industry Problem

The FAST VariVent controls are the new industry standard for commercial kitchen ventilation systems. Engineers, consultants and operators are specifying them on thousands of hoods for both new and existing stores.

Savings & Benefits

The VariVent controls improve hood efficiency by up to 50%. Typical annual operating savings allows to payback investment within 1-3 years. They also improve kitchen comfort, indoor air quality, and fire safety.

Simple to Use

The cook/chef presses the light and fan switch on the Keypad. That's it! The hood lights then turn on and the fans go to a preset minimum speed of 10-50%. When the cooking appliances are turned on, the fan speed increases based on exhaust air temperature. During actual cooking, the speed increases to 100% until the smoke/vapor is removed.



The VariVent Keypad is easy to operate.

Most commercial kitchen hoods operate at 100% capacity all day, even during idle non-cooking periods. This costs the food service industry over \$2 billion in wasted energy every year.

The FAST VariVent controls are the only proven solution to this problem. Using a microprocessor and sensors, they reduce fan speed during idle periods to save conditioned air, and both fan and/or heating energy.

The VariVent controls can be installed on new hoods or be retrofitted on existing hoods.

Save Up to 50 %
in Kitchen Hood Energy Costs, and helps
reduce Greenhouse Gas Emissions (GHG).





When Time Matters!

VariVent (Energy Control System)

Proven Technology & Easy to Operate

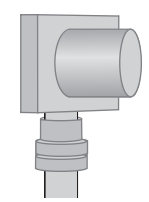

The Temperature Sensor monitors the exhaust air temperature in the duct. A signal is transmitted to the I/O Processor to vary the fan speed in proportion to the actual heat load. (To optimize energy savings and kitchen comfort, additional temperature sensors can monitor the outside air and kitchen space temperature.)

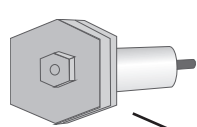

The Air Purge Units prevent grease vapors from entering the Optic Sensor housings and collecting on the lenses. Minimizes the need for wiping off lenses to once a month, typically. (Not required for heat-only applications.)

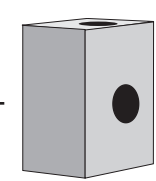
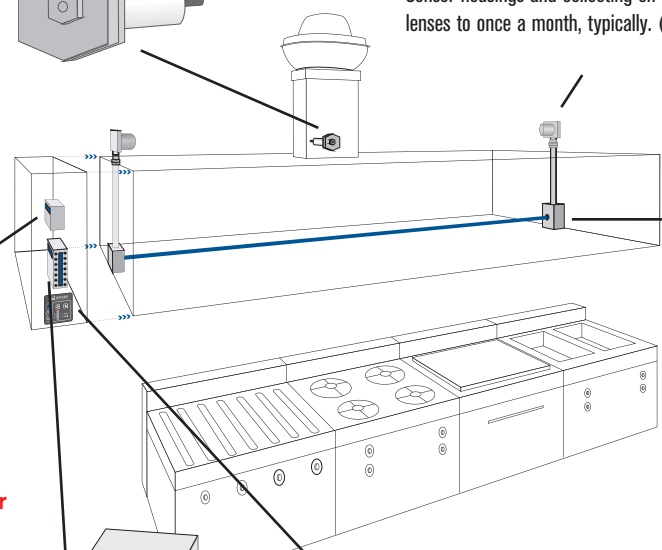

The Electronic Motor Starter is a VFD that receives a start/stop command and a 4-20mA signal from the I/O Processor. It varies the fan speed between a minimum and maximum setting based on the actual heat and smoke load.

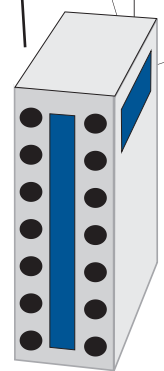

The Optic Sensors monitor when actual cooking is taking place. Upon the detection of any smoke/vapors inside the hood, they send a signal to the I/O Processor to speed up the fans to 100% until the effluent is effectively removed. (Not required for heat-only applications.)

The I/O Processor controls the lights and/or fans for up to four hoods. It is typically mounted in an end-cabinet, and communicates between the hood sensors and Electronic Motor Starter(s) via plug-and-play cables (RJ-45). It is also connected to the Keypad mounted on the front face of one of the hoods for easy user interface.



The Keypad provides a wide range of functions: light and fan operation, 100% bypass capability, system setup (minimum speed, temperature span) and monitoring (fan speed percentage, temperature, diagnostics). One Keypad can control up to two I/O Processors or 8 hoods.

Approvals
UL Listed, CSA Listed, CE; complies with all applicable codes and standards including NFPA 96, IMC, BOCA, SBCCI, UMC and NSF.



When Time **Matters!**

VariVent (Energy Control System)



The New Standard in Kitchen Ventilation

Savings & Benefits

Improves Energy Efficiency

The VariVent controls improve energy efficiency by reducing the exhaust and make-up fan speeds during idle periods. Typical annual operating savings allows to payback investment within 1-3 years

Improves Kitchen Comfort

The VariVent controls improve kitchen comfort by reducing the supply of hot/humid make-up air during idle periods. They also serve as an economizer when indoor and outdoor conditions are right for free cooling.

Finally, the VariVent controls reduce hood noise in the kitchen up to 90% when the fans slow down.

Improves Fire Safety

The VariVent controls can improve fire safety by monitoring the exhaust air temperature. If the temperature approaches the fusible link rating of the fire suppression system, an alarm can sound and/or the cooking appliances can be shut down.

Improves Occupant Health

The VariVent controls can improve indoor air quality (IAQ) by monitoring the CO levels in the dining area. The exhaust and outside air quantities can be increased to 100% if the level exceeds a certain threshold.

Helps to reduce Greenhouse Gas Emissions (GHG).

Other VariVent Advantages

1. Eliminate drive losses and belt maintenance by specifying direct drive fans.
2. Reduce humidity problems associated with a negative building pressure.
3. Improve hood and building air balance with variable speed controls (versus belts and pulleys).
4. Extend HVAC equipment life by reducing run time and thus wear/tear of compressors, motors, heaters, etc.
5. Reduce grease on roof and inside ducts and fans by reducing the "transport" velocity.



When Time *Matters!*

VariVent (Energy Control System)

Before-and-After Energy Savings

Actual reading from a current VariVent customer.

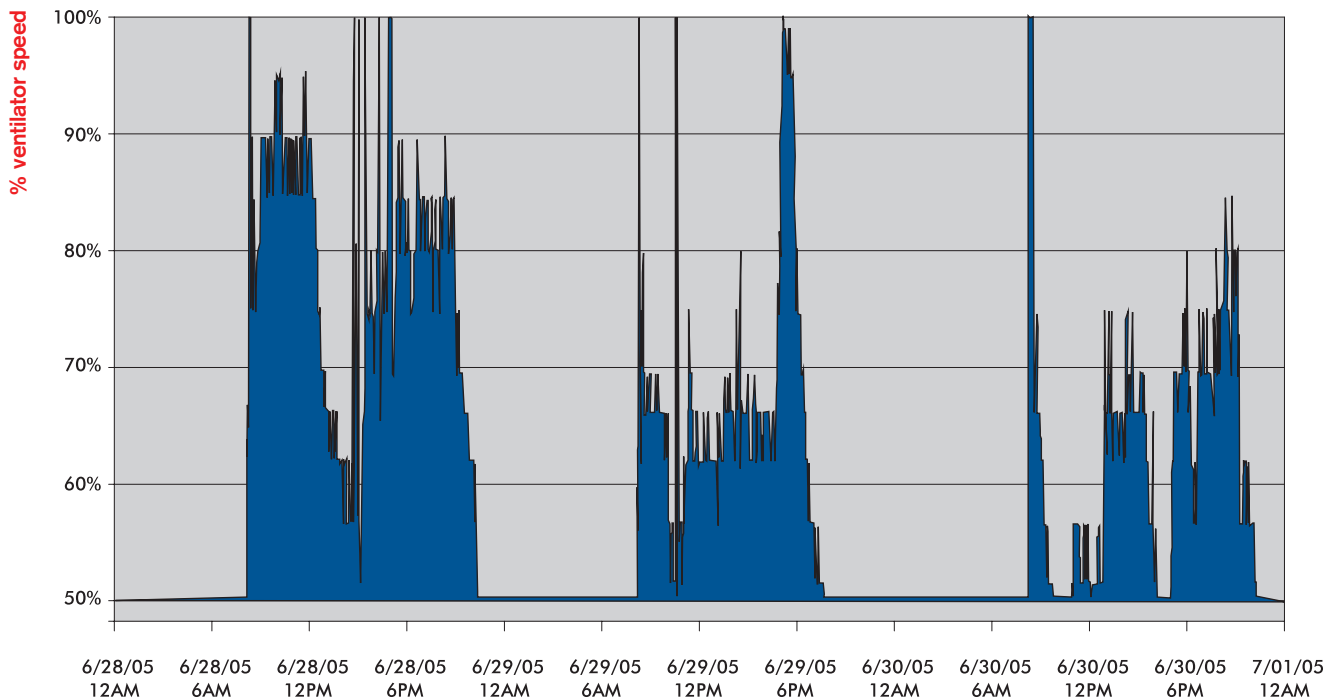

Case Studies

Supermarket

Annual energy savings
per location
\$ 4,680

Current payback
1.8 years

Hotel

Annual energy savings
per location
\$ 20,000

Current payback
1.3 years

Restaurant

Annual energy savings
per location
\$ 4,140

Current payback
2.2 years

University

Annual energy savings
per location
\$ 17,000

Current payback
1.8 years