

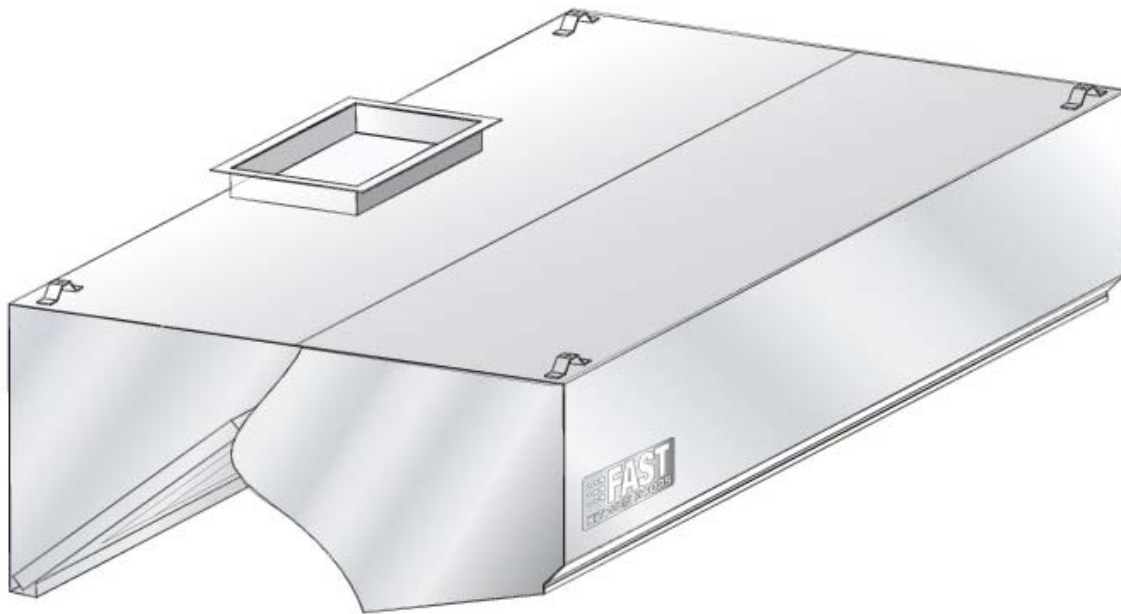

Commercial Kitchen Hood

Installation, Operation and Maintenance Manual

Version April 2022



www.fastkitchenhood.com

General Information



Prior to installing the stainless steel ventilation hood, the installing contractor should thoroughly review the plans and specifications of the project. The contractor should determine the exact location of the cooking hood and it should be determined if adequate room is available to install all ductwork with proper clearances from combustible material.

Installation of the hood must be in accordance with NFPA96, Removal of Smoke and Grease-Laden Vapors from Commercial Cooking Equipment.

It is also imperative that the roof top package or curbs be installed in such a way as to minimize any offsetting in the exhaust duct system. All overhead beams or angles must be structurally strong enough to support the weight of the hood system. It is often necessary to strengthen existing structural beams, as they are not designed to carry the weight of a stainless steel hood. NFPA 96, BOCA, the Southern Building Code and local authorities having jurisdiction call for minimum clearances between the cooking hood, exhaust ducts and building materials which are combustible. The normal requirement between the hood, duct and combustible materials is an 18" clearance. However, this clearance can be lowered based on NFPA 96 Appendix A, BOCA or UMC Codes. It is important that you check with local authorities having jurisdiction to make sure the method of installation is suitable and satisfactory with their requirements.

Contact

Should more information be needed please call us at **1-866-439-7984** or send us an email at info@fastkitchenhood.com



Table of Contents

Installation	4
Preparation	4
Clearance Reduction	4
Single Wall or Island Hood Installation	5
End to End Hoods.....	10
Back to Back Hoods.....	10
Ductwork Installation.....	11
Installation of Hood Accessories.....	12
Supply Plenum Installation	12
Enclosure Panel Installation.....	12
End Panel installation.....	13
Backsplash Installation.....	13
Hood Performance Table	14
USA Performance Table	14
Canada Performance Table.....	17
Operation	21
Performance Evaluation.....	21
Calculating Supply CFM Rate	21
Calculating Exhaust CFM Rate.....	22
Balancing.....	22
Maintenance	23
Daily Maintenance	23
Weekly Maintenance	23
Periodic Maintenance	24
Maintenance Documentation.....	25



Installation

Preparation

Upon receipt of product ensure that all items are included referencing the packing list. When uncrating the hood ensure that there are no dents or scratches and report any damage to the delivering freight carrier and file a claim if appropriate.

Check the nameplate on the given equipment to ensure it meets the given specification, otherwise notify the manufacturer. Proper clearance need to be given during installation, the hood should be placed in proximity to where it will be installed. Check with Authorities Having Jurisdiction on the minimum clearance needs for the specific environment. NFPA standard 4.2 calls for a minimum clearance of 18 inches from combustibles, 3 inches from limited combustibles and zero clearance from non-combustibles.

Ensure that the support structure can hold the weight of the hood by contacting the contractor or structural engineer.

Clearance Reduction

Clearance reduction is possible to 3” from limited combustibles or zero clearance from combustible materials as evaluated by UL 710. The hood may be installed to follow these clearances in the following manner.

Zero clearance ULc File number MH446941

- Surfaces of the hoods (sides option S and/or top option T) with a factory installed UL/ULc 1” insulated panel can be installed directly against a combustible surface
- Hood back surface with a factory installed UL/ULc 3” standoff with 1” insulated (Option BS) panel can be installed directly against a combustible surface.
- Only the surfaces of the hood in direct contact with a combustible surface need to be insulated with a 1” UL/ULc factory installed spacer. All other surfaces of the hood and combustible surface (wall, ceiling, etc) do not need to be insulated to keep the zero inch clearance rating.



Single Wall or Island Hood Installation

1. Complete pre-installation preparation as outlined above and have the hood positioned in its final position.
2. If the hood was included with any thermostats or sensors install them now.
3. If possible and non-interfering to installation, weld the exhaust duct to the exhaust collar while the hood is on the floor.
4. Use 3/8" threaded rods to hang hoods. Drill 7/16" holes in the supporting structure to line up with the welded-on angle mounting brackets on the hood. (The structural integrity of the structural support system is the responsibility of the contractor and the structural engineer.) The whole spacing should line up with the angle brackets on top of the hood.
5. Threaded rods should be 3/8" closer to the back wall at the top hanger so as to pull the hood against the wall. (see illustration #1)

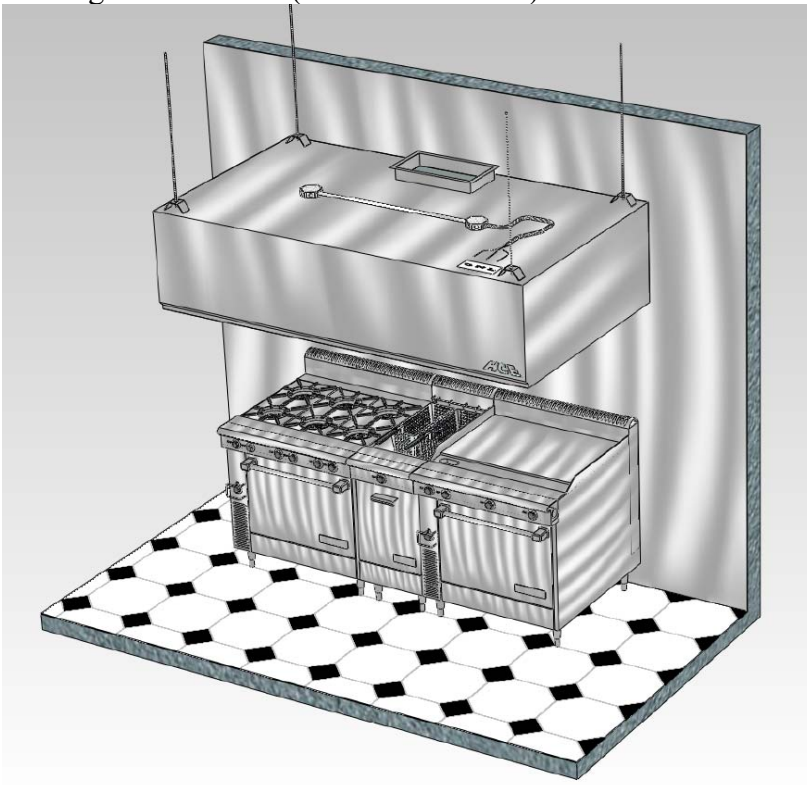

(Illustration #1)



- The hood should be hung so that the bottom of the hood is a minimum of 38" above the cooking surface, unless otherwise specified by local authorities having jurisdiction. With the hood well protected against possible scratching, lift the hood into position using high lifts or equipment jacks. When the hood is elevated to the proper height, install 3/8" threaded rod between each mounting bracket on the hood and the modified support. Secure rods with heavy duty nuts and appropriately sized fender washers.

Note: If enclosures were included the distance from the ceiling to the top of the hood is the height of the enclosure.

- Once raised ensure that the hood is level with all rods having an even weight distribution.
- If the hood was supplied with side or front supply plenums, install them now
- If the hood is shipped without an exhaust collar attached to it follow the NFPA96 detail of sealed hood – duct connection (Illustration #2).

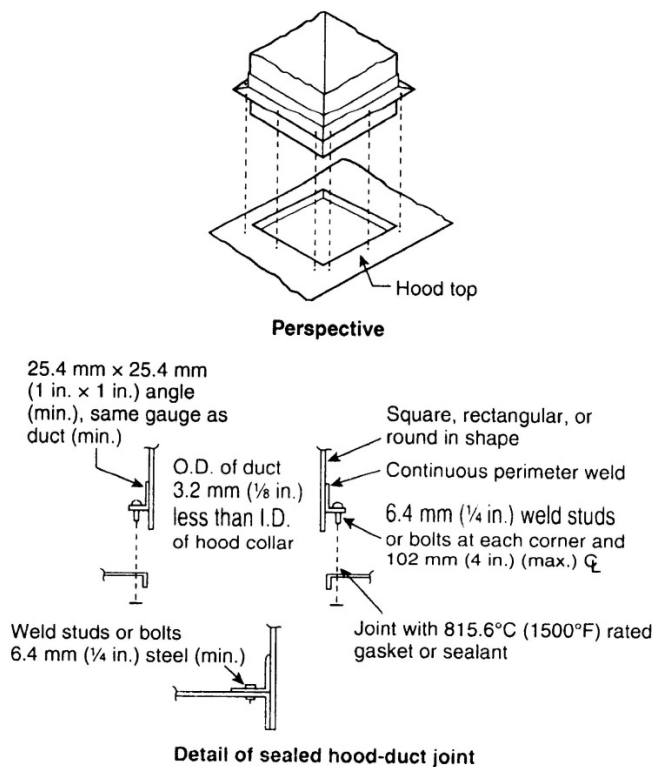

(Illustration #2)



10. For  listed hood only, shipped with a loose collar. Collar must be continuously welded, liquid tight to the hood. See instructions bellow:

- A) Mark the position of collar on the exhaust section of the hood behind the grease filters
- B) Trace the collar opening by placing the supplied collar on the hood
- C) Cut out the opening
- D) Weld supplied loose collar to the hood liquid tight

DETAIL OF FIELD WELDED COLLAR
(SHIPPED LOOSE)

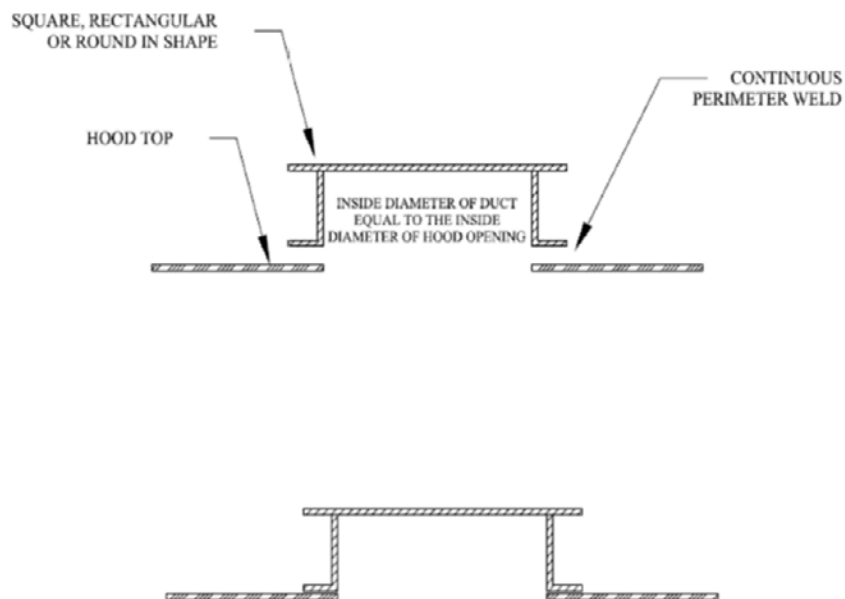

11. The exhaust ductwork can now be installed (see the Ductwork Installation section). The entire exhaust duct system must be continuously welded, liquid tight. The duct must be welded to the hood exhaust collar and the roof curb cap must be welded to the exhaust duct.



12. If the hood comes with a wall mount electrical control panel it is the responsibility of the jobsite electrician to wire the temperature sensors and hood lights properly. Refer to Illustration #3 for the electrical light connection.

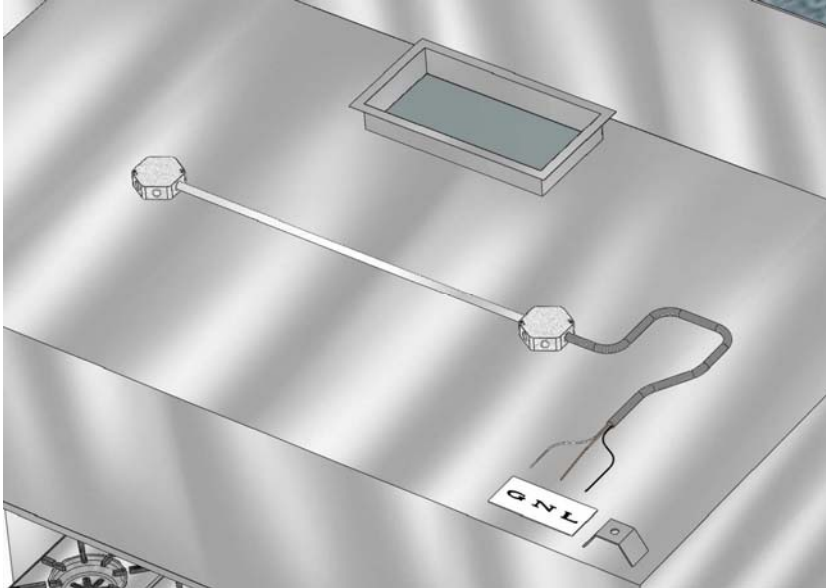

(Illustration #3)

13. If the hood requires a fire suppression system a certified fire suppression technician has the responsibility to properly install and test the system once the ductwork is completed so that it meets fire suppression system manufacturer specifications and local fire codes.
14. If enclosures, end skirts or backsplash were included install them now and refer to the *Enclosure Panel Installation* section.
15. Caulk the lower edge of the hood along the wall if applicable.
16. Install light bulbs (supplied by others), light globes, and grease filters in the hood.
17. Install grease cups provided.
18. Use a stainless steel polish such as "Sheila Shine" to clean the hood of dust or dirt acquired in transit.



19. It is recommended that a protective plastic coating be placed over the hood until construction is complete, so as to avoid any damage to this equipment.

Note: For no reason should any grease containment compartment be punctured for ease of installation or otherwise.



End to End Hoods

1. Follow steps 1 through 8 for *Single Wall or Island Hood* installation for each hood.
2. Adjust the threaded rods from which the hoods are hung so that the hoods are flush and level with each other.
3. Once the hoods are hung proceed to follow steps 9 through 14 for a *Single Wall or Island Hood* installation.
4. The hoods should have a gap of less than or equal to a 1/8th of an inch, if not they should be repositioned until they do. Caulk the gap between the hoods with a bead of silicone sealant larger than the gap. If provided slip the according trim pieces over the sealed gaps.
5. Proceed to steps 15 through 19 of for *Single Wall or Island Hood* installation.

Back to Back Hoods

1. Follow steps 1 through 8 for *Single Wall or Island Hood* installation for each hood.
2. Adjust the threaded rods from which the hoods are hung so that the hoods are flush and level with each other.
3. Once the hoods are hung and interconnected proceed to follow steps 9 through 14 of for *Single Wall or Island Hood* installation.
4. The hoods should have a gap of less than or equal to a 1/8th of an inch, if not they should be repositioned until they do. Caulk the gap between the hoods with a bead of silicone sealant larger than the gap. If provided slip the according trim pieces over the sealed gaps.
5. Proceed to steps 15 through 19 of for *Single Wall or Island Hood* installation.



Ductwork Installation

Ductwork must be installed according to local codes and restrictions. It is the responsibility of the installer to ensure that the ducts are installed properly to code.

NFPA 96, chapter 7, indicated the manner in which ducts must be installed. Use the following as a guideline.

1. Install the ducts with minimal bends and turns, plan route first.
2. Ducts shall be constructed and supported by carbon steel not less than 1.52 mm (0.060 in) (No. 16 MSG) in thickness or stainless steel not less than 1.21mm (0.048in) (No. 18 MSG) in thickness.
3. All seams, joints, penetration and duct to hood collar connections shall have a liquid tight continuous external weld. This is not the case for certain duct to hood connections and other devices with a grease tight connection, check with your local Authority Having Jurisdiction. Refer to NFPA 7.5.5 for accepted welded connections.

Note: Internal welding is permitted given that it is formed ground smooth and accessible for inspection.

4. Access doors are required on the sides or top of the duct, whichever is more accessible, and at changes in direction.
5. Access doors are also needed when a fusible link is installed with a damper within 18 inches of the damper
6. Access panels are to be made from the same material and thickness as the duct, having a gasket rated for 1500°F (815.6°C) grease tight and fasteners must be made from carbon or stainless steel without puncturing duct walls.
7. Do not use flexible ducts for supply ducts.



Installation of Hood Accessories

Supply Plenum Installation

1. Unpack plenum assembly making sure not to scratch or dent it. If there is any damage upon receipt report any damage to the delivering freight carrier and file a claim if appropriate.
2. If the supply collar needs to be cut to size do so now.
3. Use 3/8" threaded rods to hang plenums. Drill 7/16" holes in the supporting structure to line up with the welded-on angle mounting brackets on the plenum.
4. Connecting brackets are welded onto the plenum with the intention of leaning against the edge of the hood where the plenum is being installed. Before raising the plenum remove the plastic coating which will be covered by the hood.
5. Position and orientate the plenum in accordance to project drawings.
6. Raise the plenum to the proper height (until the top of plenum lines up with the top of the hood) and secure to support structure with 3/8" threaded rods then secure rods with heavy duty nuts and appropriately sized fender washers. Ensure the welded connecting bracket is resting on top of the hood.
7. Install additional plenums if applicable.

Enclosure Panel Installation

1. Unpack enclosure panels making sure not to scratch or dent them. If there is any damage upon receipt report any damage to the delivering freight carrier and file a claim if appropriate.
2. Position the end enclosure on the hood and either clamp, rivet or tack-weld the panels into place.
3. Fasten the end enclosures to the wall using screws or other means of attachment according to wall constructions.
4. If the hood is double island configuration then bolt the end panels from each hood to each other.
5. Position the front enclosure panel and bolt to end enclosure panels.
6. Clamp, rivet or tack-weld the front enclosure panel to the hood.
7. Caulk with silicone any external seams.



End Panel installation

1. Unpack end panels making sure not to scratch or dent them. If there is any damage upon receipt report any damage to the delivering freight carrier and file a claim if appropriate.
2. For location of end panels refer to project drawing.
3. Take the kinked end of the end panel and position it below the hem of the hood. Bolt the end panel to the hood.
4. Using sheet metal screws attach the end panel to the wall.
5. Caulk with silicone and gaps between end panel and the hood.

Backsplash Installation

1. Unpack backsplash panel making sure not to scratch or dent them. If there is any damage upon receipt report any damage to the delivering freight carrier and file a claim if appropriate.
2. For location and orientation of backsplash panel refer to project drawing.
3. Position the backsplash with the flange position behind the hood, if it is a flat backsplash divider bars will needed to be installed.
4. If a divider bar is needed drill holes in the wall and bolt the divider to the wall. Use adhesive as well as divider bars to secure the backsplash to the wall.
5. Caulk any joints with silicone between the hood and backsplash.

Lights

When replacing glass globe, replace with thermal and shock resistant tempered glass globe with clear plastic coating.



Hood Performance Table

USA Performance Table

SSH model UL and ETL listed to ANSI/UL-710 standards File number MH46941

Prefix	Suffix	Acces.	Options	Description
LP				Tapered hood for low ceiling applications-
PS				Deep hoods for heavy duty cooking applications
	MKA			Front make-up air discharge
	DF			Listed filters in series
	MUA			Make-up air discharge into hood (with Fire damper)-
	C			Island type
		ED		Fire damper in exhaust
		BD		Balancing damper in exhaust
			S	0" Clearance to combustibile to side
			BS	0" Clearance to combustibile to back side
			T	0" Clearance to combustibile to top

Model name	Prefix	Suffix	Cooking Temp. rating °F	Min. Exhaust Airflow CFM/Ft	Max. Supply Airflow CFM/Ft
SSH	LP	-	212,400,600	100,250,420	



	LP	DF	212,400,600	100,250,420	
	LP	MUA	212,400	100,250	50,125
	LP	C	212,400	100,250	
	LP	MKA	212,400	100,250	80,125
SSH	-	-	212,400	100,250	
	-	-	600	420	
	-	-	700	550	
	-	DF	212,400,600	100,250,420	
		DF	700	550	
	-	MUA	212,400	100,250	50,125
	-	C	212,400	100,250	
	-	MKA	212,400	100,250	
SSH	PS	-	212,400	100,250	
	PS	-	600	420	
	PS	-	700	550	
	PS	DF	212,400,600	100,250,420	
	PS	DF	700	550	
	PS	MUA	212,400	100,250	50,125
	PS	C	212,400	100,250	
	PS	MKA	212,400	100,250	

The following options available on series GED (Dry grease extractor baffles) only:

Prefix	Suffix	Option	Description
LP			Tapered hood for low ceiling applications-
PS			Deep hoods for heavy duty cooking applications
	AW		Auto wash
	CM		Cold-water mist

MKA Front make-up air discharge

	C		Island type
		ED	Fire damper in exhaust
		BD	Balancing damper in exhaust

Model name	Prefix	Suffix	Cooking Temp. rating °F	Min. Exhaust Airflow CFM/Ft	Max. Supply Airflow CFM/Ft
GED	LP	-	212,400	100,250	
	LP	AW	212,400	100,250	
	LP	CM	212,400	100,250	



	LP	C	212,400	100,250	
	LP	MKA	212,400	100,250	80,125
GED	-	-	212,400	100,250	
	-	AW	212,400	100,250	
	-	CM	212,400	100,250	
	-	C	212,400	100,250	
	-	MKA	212,400	100,250	80,125
GED	PS	-	212,400	100,250	
	PS	AW	212,400	100,250	
	PS	CM	212,400	100,250	
	PS	C	212,400	100,250	
	PS	MKA	212,400	100,250	

GENERAL INFORMATION:

Hood must overhang cooking surface (not cooking equipment):

- at least 300 mm (12 in.) to the front for all models except SSH
- at least 150 mm (6 in.) to the front for SSH
- at least 150 mm (6 in.) to the sides.

The lower front edge of the hood must be at least 965 mm (38 in.) above the cooking surface for 600F and below. For Solid Fuel cooking distance between cooking surface and the lower edge of the filters must be at least 1219 mm (48 in.).

-The exhaust and supply (when provided) air flow rates were established under controlled laboratory conditions; and

-Greater exhaust and/or lesser supply air is required for complete vapor and smoke removal in specific installations.



Canada Performance Table

SSH model ULc and ETLc listed to CAN/ULC-S646 standards, ULc File number MH446941 and ETLc file number 100628400SAT-001.

Prefix	Suffix	Acces.	Options	Description
LP				Tapered hood for low ceiling applications-
PS				Deep hoods for heavy duty cooking applications
	MKA			Front make-up air discharge
	DF			Listed filters in series
	MUA			Make-up air discharge into hood (with Fire damper)-
	C			Island type
		ED		Fire damper in exhaust
		BD		Balancing damper in exhaust
			S	0" Clearance to combustible to side
			BS	0" Clearance to combustible to back side
			T	0" Clearance to combustible to top

All hoods may be provided with incandescent, fluorescent or led lighting fixtures and Grease Filters bear cULus labels.

Model name	Prefix	Suffix	Cooking Temp. rating °F	Min. Exhaust Airflow CFM/Ft	Max. Supply Airflow CFM/Ft
SSH	LP	-	300,400,550	100,250,350	
	LP	-	600	420	
	LP	-	700	500	
	LP	DF	300,400,550	100,250,350	



	LP	DF	600,700	420,500	
	LP	MUA	300,400,550	100,250,350	50,125,170
	LP	C	300,400,550	100,250,350	
	LP	C	700	500	
	LP	MKA	300,400,750	100,250,500	80,125,400
SSH	-	-	300,400,550	100,250,350	
	-	-	600	420	
	-	-	700	500	
	-	DF	300,400,550	100,250,350	
	-	DF	600	420	
	-	DF	700	500	
	-	MUA	300,400,550	100,250,350	50,125,170
	-	C	300,400,550	100,250,350	
	-	C	700	500	
	-	MKA	300,400,750	100,250,500	80,125,400
SSH	PS	-	300,400,550	100,250,350	
	PS	-	600	420	
	PS	-	700	500	
	PS	DF	300,400,550	100,250,350	
	PS	DF	600	420	
	PS	DF	700	500	
	PS	MUA	300,400,550	100,250,350	50,125,170
	PS	C	300,400,550	100,250,350	
	PS	C	700	500	
	PS	MKA	300,400,750	100,250,500	80,125,400

The following options available on series GED (Dry grease extractor baffles) only:

Prefix	Suffix	Option	Description
LP			Tapered hood for low ceiling applications-
PS			Deep hoods for heavy duty cooking applications
	AW		Auto wash
	CM		Cold-water mist
	MKA		Front make-up air discharge
	C		Island type
		ED	Fire damper in exhaust



		BD	Balancing damper in exhaust
--	--	----	-----------------------------

All hoods may be provided with incandescent, fluorescent or led lighting fixtures bear cULus labels.

Model name	Prefix	Suffix	Cooking Temp. rating °F	Min. Exhaust Airflow CFM/Ft	Max. Supply Airflow CFM/Ft
GED	LP	-	300,400,550	100,250,350	
	LP	-	700	500	
	LP	AW	300,400,550	100,250,350	
	LP	AW	700	500	
	LP	CM	300,400,550	100,250,350	
	LP	CM	700	500	
	LP	C	300,400,550	100,250,350	
	LP	C	700	500	
	LP	MKA	300,400,750	100,250,500	80,125,400
GED	-	-	300,400,550	100,250,350	
	-	-	700	500	
	-	AW	300,400,550	100,250,350	
	-	AW	700	500	
	-	CM	300,400,550	100,250,350	
	-	CM	700	500	
	-	C	300,400,550	100,250,350	
	-	C	700	500	
	-	MKA	300,400,750	100,250,500	80,125,400
GED	PS	-	300,400,550	100,250,350	
	PS	-	700	500	
	PS	AW	300,400,550	100,250,350	
	PS	AW	700	500	
	PS	CM	300,400,550	100,250,350	
	PS	CM	700	500	
	PS	C	300,400,550	100,250,350	
	PS	C	700	500	
	PS	MKA	300,400,750	100,250,500	80,125,400

GENERAL INFORMATION:

Hood must overhang cooking surface (not cooking equipment):

- at least 300 mm (12 in.) to the front for all models except SSH
- at least 150 mm (6 in.) to the front for SSH
- at least 150 mm (6 in.) to the sides.



The lower front edge of the hood must be at least 965 mm (38 in.) above the cooking surface for 600F and below. For Solid Fuel cooking distance between cooking surface and the lower edge of the filters must be at least 1219 mm (48 in.).

-The exhaust and supply (when provided) air flow rates were established under controlled laboratory conditions; and

-Greater exhaust and/or lesser supply air is required for complete vapor and smoke removal in specific installations.



Operation

According to NFPA 96 commercial cooking areas must prevent negative pressures exceeding 4.98 Pa. Commercial kitchen ventilation systems are appropriately sized and installed to keep to local requirements, manufacturer specification and to be approved by local Authorities Having Jurisdiction. Determining whether or not your ventilation system is functioning properly will require measuring the exhaust and supply air displacement rates to determine if your system is balanced. Test your system by a trained professional before running cooking appliances.

Before doing a performance evaluation ensure the following:

- All fans are operational and oriented in the proper exhaust/supply direction.
- All filters are installed
- All kitchen cooking equipment and exhaust equipment is installed and functional.
- HVAC systems are installed and functional

Performance Evaluation

To perform an evaluation of the ventilation system a velometer or other device to measure velocity is needed. The cross sectional area of the inlet and outlet of the system are needed as well to calculate the inlet and exhaust CFM rates.

Calculating Supply CFM Rate

1. Calculate the area of the supply plenum using the following formula:

$$\text{Area (ft}^2\text{)} = \text{Length (ft)} \times \text{Width (ft)}$$

2. Record multiple velocity readings through the supply openings at multiple locations along the length of the supply plenum. If a vane anemometer is used, hold it approximately 2 inches from opening and hold it parallel to the opening of the plenum.
3. Calculate the average velocity through the supply opening.
4. Calculate the CFM using the following equation:

$$\text{CFM} = \text{Free area (ft}^2\text{)} \times \text{Average Velocity (ft/min)}$$



Calculating Exhaust CFM Rate

1. Record Filter sizes and compute the free area of the filters, ex:

$$16''\times 16'' = 14\times 14 = 1.36 \text{ ft}^2$$

$$10''\times 20'' = 8\times 18 = 1.00 \text{ ft}^2$$

$$12''\times 16'' = 10\times 14 = 0.97 \text{ ft}^2$$

2. Take multiple velocity readings from left to right along the length of the filters and record the readings.
3. Compute the average velocity through each filter.
4. Calculate the CFM through each filter with the following formula:

$$\text{CFM} = \text{Free area (ft}^2\text{)} \times \text{Average Velocity (ft/min)}$$

5. Total the exhaust CFM of each filter and hood.
6. Multiply the CFM by the appropriate k-factor for the particular measuring device used.

Balancing

Determine if whether the ventilation system is adjusted properly using the calculated CFM rates. The room for which the cooking equipment is used in should have a slight negative pressure. If not balanced adjust fans to get the desired room pressure.



Maintenance

Keeping exhaust system and accessories clean will keep them running well and safely. The hood should have a regular maintenance schedule and routine for which a maintenance log is kept for record. NFPA 96 chapter 11.6 demands an exhaust system free of contamination and grease-laden deposits as well as certifications of inspection and cleaning. Visual inspections should be done often to see if cleaning is required.

Daily Maintenance

- Empty and clean the grease drain and collection cup
- Using a cloth either damp with water or water and detergent mixture, wipe down the surfaces of the hood in the direction of stainless steel grain removing any stains or dirt.
- If detergent was used wipe again with a damp cloth with water. Dry all wet surfaces.
- Apply a stainless steel polish.

Weekly Maintenance

- Remove all filters or cartridges and wash in a dishwasher or soak in a sink with a water and detergent mixture.
- If cooking equipment is used for heavy duty application weekly maintenance should be done more frequently or daily.
- Before re-installing filters clean the interior of grease.



Periodic Maintenance

- Perform a complete visual inspection of the exhaust system for grease, leaks or damage.
- Check fan for wear and alignment.
- Inspect fusible link if applicable
- Clean all exterior and reachable interior surface with a mild detergent.
- Prevent grease accumulation in ductwork and clean when necessary to keep system to code.
- If necessary re-caulk gaps

Note: Refrain from using steel wool, SOS pads, scrappers or other abrasive cleaning product they may scratch the stainless steel surface. Avoid chlorine based cleaners and always clean in the direction of the grain opposed to circles.



